

1.25Gb/s SFP 1550nm 80km Transceiver

TS551AZ-EN Product Specification

FEATURES

- Typical data rate 1.25Gbps
- 1550nm DFB Laser and PIN photo detector
- Duplex LC receptacle
- Single +3.3V power supply
- Hot-pluggable
- International Class1 laser safety certified
- Operating temperature range: -20 ~ +85°C
- RoHS Compliant
- Support Digital Diagnostic Monitoring interface
- Max reach 80km over SMF

APPLICATIONS

- Point-to-Point networking
- SONET OC-24
- Other Optical Links

ORDERING INFORMATION

Part Number	Form Factor	Data Rate	Media	Distance (km)	Wavelength (nm)	Temperature (°C)
TS551AZ-EN	SFP	1.25Gbps	SMF	80	1550	-20~85

ABSOLUTE MAXIMUM RATINGS

Exceeding the limits below may damage the transceiver permanently.

Parameter	Symbol	Min	Typ	Max	Unit.	Note
Storage Temperature	TSTG	-40	-	85	°C	
Operating Relative Humidity	RH	5	-	95	%	
Supply Voltage	VCC	-0.5	-	4	V	

RECOMMENDED OPERATING CONDITIONS

Parameter	Symbol	Min	Typ	Max	Unit.	Note
Operating Case Temperature	Tc	-20	-	85	°C	
Supply Voltage	VCC3	3.13	3.3	3.47	V	
Supply Current	ICC3	-	-	300	mA	+3.3V Supply
Data Rate	DR	-	1.25	-	Gbps	

ELECTRICAL and OPTICAL CHARACTERISTICS

Parameter	Symbol	Min	Typ	Max	Unit.	Note
Transmitter@1.25Gbps						
Tx Differential Input Amplitude	Vin p-p	200	-	2400	mV	
Input Differential Impedance	Zin	-	100	-	Ω	
Output Optical Power	PO	0	-	5	dBm	
Extinction Ratio	ER	9	-	-	dB	
Center Wavelength Range	λ_c	1520	1550	1580	nm	
Spectrum Width(-20dB)	$\Delta \lambda$	-	-	1	nm	
Side Mode Suppression Ratio	SMSR	30	-	-	dB	
Optical Return Loss Tolerance	RL	12	-	-	dB	
Output Optical Eye	Compliant with G.957					
Tx Disable Voltage	VOH	2	-	VCC	V	LVTTL
	VOL	0	-	0.8	V	LVTTL
Optical Power at Tx Disable	Ptxdis	-	-	-45	dBm	
Receiver@1.25Gbps						
Rx Differential Output Amplitude	Vout p-p	300	-	800	mV	
Receiver Optical Wavelength	λ_c	1270	-	1580	nm	
Receiver Sensitivity	Sen	-	-	-24	dBm	Note 1
Receiver Overload	OL	-3	-	-	dBm	
LOS Voltage	Normal	2	-	Vcc+0.3	V	LVTTL
	Fault	0	-	0.8	V	LVTTL
LOS Assert Level	LOSA	-38	-	-	dBm	
LOS De-Assert Level	LOSD	-	-	-26	dBm	
LOS Hysteresis	LOSH	0.5	-	6	dB	

Notes:

1. Measured with 2⁷-1 NRZ Pattern. BER≤1E-12@1.25Gpbs, ER=9dB

Digital Diagnostic Functions

Parameter	Symbol	Min.	Max.	Unit	Repeatability	Notes
Temperature	DDMI_Temp	-3	3	°C	± 1°C	1LSB=1/256°C
Supply Voltage	DDMI_VCC	-3%	3%	V	± 1 %	1LSB=0.1mV
Bias Current	DDMI_Ibias	-10%	10%	mA	± 5 %	1LSB=2uA
TX Optical Power	DDMI_TX	-3	+3	dB	± 0.5 dB	1LSB=0.1uW
RX Optical Power	DDMI_RX	-3	+3	dB	± 1.5 dB	1LSB=0.1uW

PIN DIAGRAM

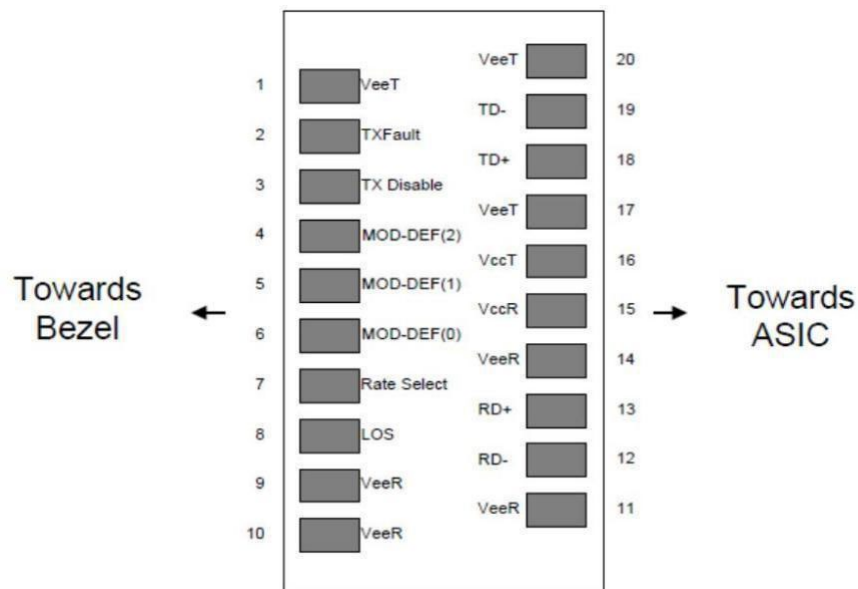

PIN DESCRIPTIONS

Pin	Symbol	Description	Notes
1	VeeT	Transmitter Ground (Common with Receiver Ground)	5
2	TX_Fault	Transmitter Fault, Low: normal; High: abnormal	1
3	TX_Disable	Transmitter Disable High: Transmitter off Low: Transmitter on	2
4	MOD_DEF(2)	Module Definition 2. Data line for Serial ID.	3
5	MOD_DEF(1)	Module Definition 1. Clock line for Serial ID.	3
6	MOD_DEF(0)	Module Definition 0. Grounded within the module.	
7	Rate Select	No connection required	
8	LOS	Loss of Signal indication. Logic 0 indicates normal operation.	4
9	VEER	Receiver Ground(Common with Transmitter Ground)	5
10	VEER	Receiver Ground(Common with Transmitter Ground)	5
11	VEER	Receiver Ground(Common with Transmitter Ground)	5
12	RD-	Receiver Inverted DATA out. AC Coupled. CML-O	6
13	RD+	Receiver Non-inverted DATA out. AC Coupled. CML-O	6
14	VeeR	Receiver Ground	5
15	VccR	Receiver Power Supply	
16	VccT	Transmitter Power Supply	
17	VeeT	Transmitter Ground	5
18	TD+	Transmitter Non-Inverted DATA in. AC Coupled. CML-I	7
19	TD-	Transmitter Inverted DATA in. AC Coupled. CML-I	7
20	VeeT	Transmitter Ground (Common with Receiver Ground)	5

Notes:

1. TX_Fault is an open collector/drain output, which should be pulled up with a 4.7K-10K Ω resistor on the host board. Pull up voltage between 2.0V and $V_{ccT/R}+0.3V$. When high, output indicates a laser fault of some kind. Low indicates normal operation. In the low state, the output will be pulled to $< 0.8V$.
2. TX_Disable is an input that is used to shut down the transmitter optical output. It is pulled up within the module with a 4.7-10 K Ω resistor.
3. SDA and SCL should be pulled up with a 4.7K- 10K Ω resistor on the host board.
4. LOS (Loss of Signal) is an open collector/drain output, which should be pulled up with a 4.7K - 10K Ω resistor. Pull up voltage between 2.0V and $V_{ccT/R}+0.3V$. When high, this output indicates the received optical power is below the worst-case receiver sensitivity (as defined by the standard in use). Low indicates normal operation. In the low state, the output will be pulled to $<0.8V$
5. The module signal ground contacts, VeeR and VeeT, should be isolated from the module case
6. RD-/+ : These are the differential receiver outputs. They are AC coupled 100 Ω differential lines which should be terminated with 100 Ω (differential) at the user SERDES. The AC coupling is done inside the module and is thus not required on the host board.
7. TD-/+ : These are the differential transmitter inputs. They are AC-coupled, differential lines with 100 Ω differential termination inside the module. The AC coupling is done inside the module and is thus not required on the host board.

MECHANICAL SPECIFICATION

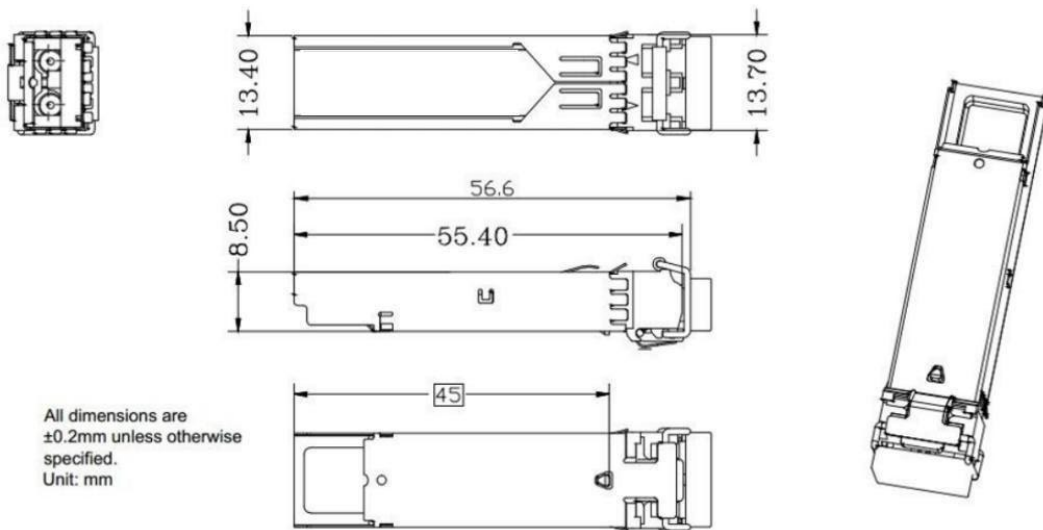

LABEL DIAGRAM



TS551AZ-EN

SFP 1.25G Duplex 1550nm 80km LC

Class 1 Laser

MADE IN CHINA

S/N: ??????????



X.XX.XX.XXX